

EE338 Ch8 Problems

***8.26** For each of the op-amp circuits shown in Fig. P8.26, identify the feedback topology and indicate the output variable being sampled and the feedback signal. In each case, assuming the op amp to be ideal, find an expression for β , and hence find A_f .

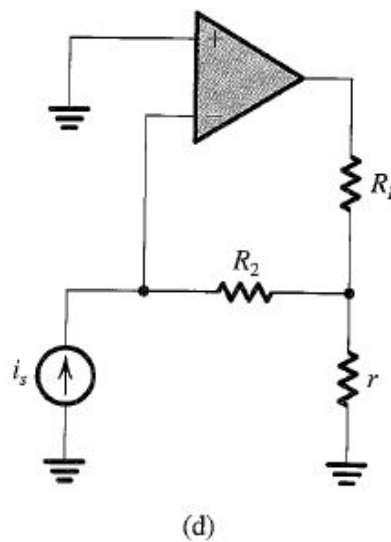
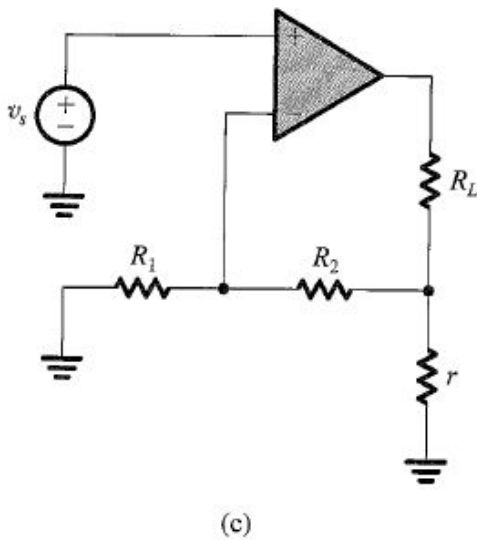
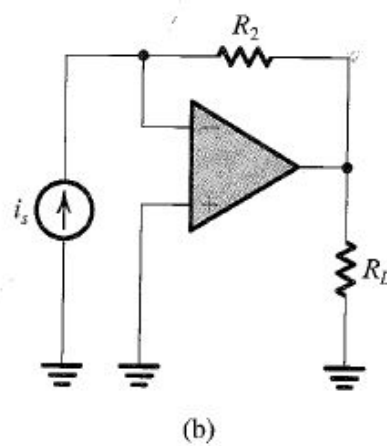
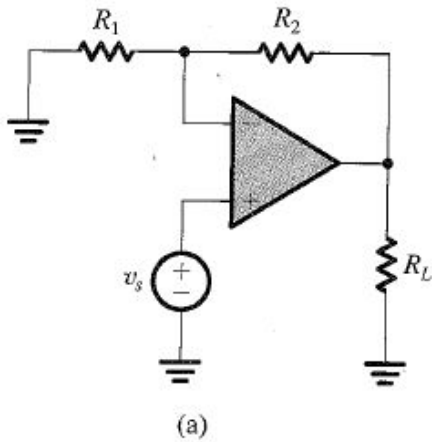

***8.32** In the series–shunt amplifier shown in Fig. P8.32, the transistors operate at $V_{BE} \cong 0.7$ V with h_{FE} of 100 and an Early voltage that is very large.

- (a) Derive expressions for A , β , R_i , and R_o .
 (b) For $I_{B1} = 0.1$ mA, $I_{B2} = 1$ mA, $R_1 = 1$ k Ω , $R_2 = 10$ k Ω , $R_s = 100$ Ω , and $R_L = 1$ k Ω , find the dc bias voltages at the input and at the output, and find $A_f \equiv v_o/v_s$, R_{in} , and R_{out} .

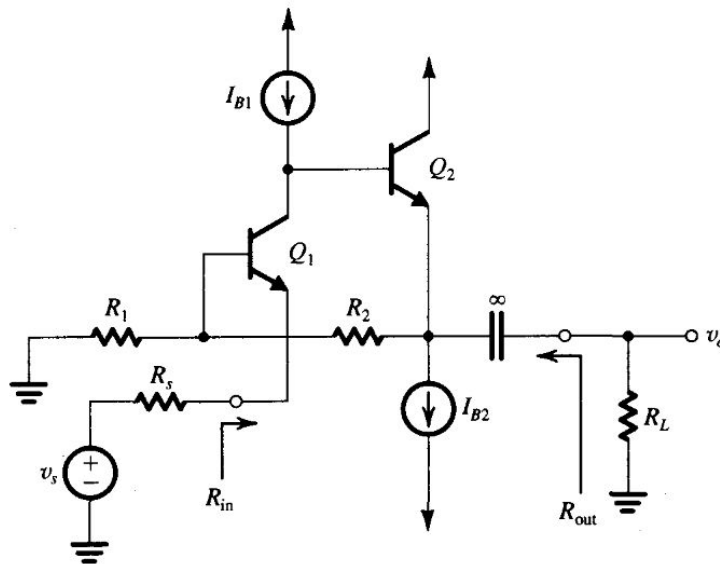

FIGURE P8.32

8.42 The shunt–shunt feedback amplifier in Fig. P8.42 has $I = 1$ mA and $V_{GS} = 0.8$ V. The MOSFET has $V_t = 0.6$ V and $V_A = 30$ V. For $R_s = 10$ k Ω , $R_1 = 1$ M Ω , and $R_2 = 4.7$ M Ω , find the voltage gain v_o/v_s , the input resistance R_{in} , and the output resistance R_{out} .

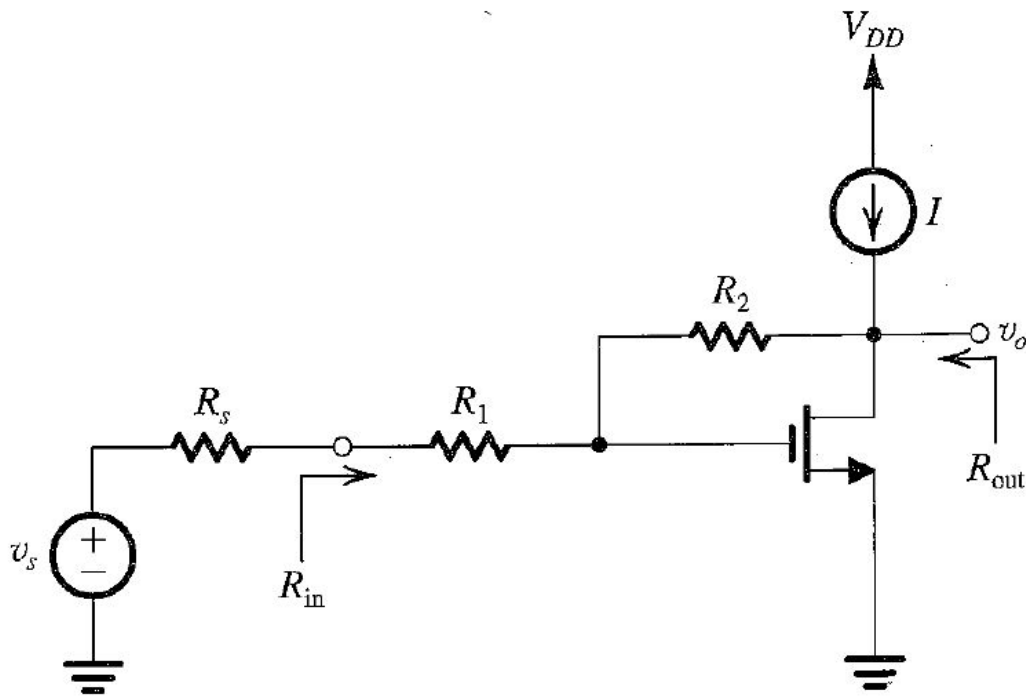

FIGURE P8.42

***8.51** For the amplifier circuit in Fig. P8.51, assuming that V_s has a zero dc component, find the dc voltages at all nodes and the dc emitter currents of Q_1 and Q_2 . Let the BJTs have $\beta = 100$. Use feedback analysis to find V_o/V_s and R_{in} .

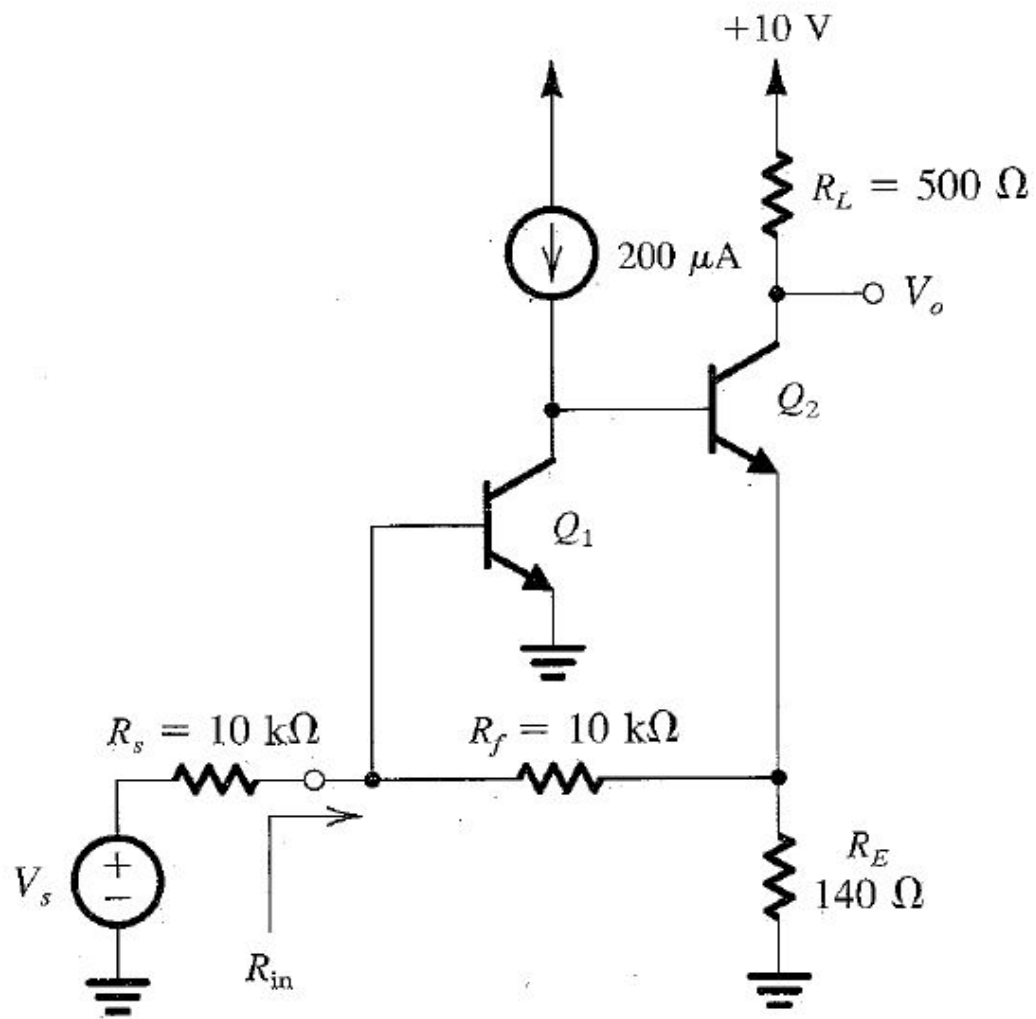

FIGURE P8.51